



Mark Roberts Motion Control

TALOS



QUICK START GUIDE

Document version: TALOS-QSG-20160331

Part number: MRMC-1165-03

Talos Quick Start Guide

Document version: TALOS-QSG-20160331

Part number: MRMCMC-1165-03

© 2016 Mark Roberts Motion Control Ltd. All rights reserved.

No part of this publication may be reproduced, transmitted, or translated by any means — graphical, electronic, or mechanical — including photocopying, recording, taping, or storage in an information retrieval system, without the express written permission of Mark Roberts Motion Control.

Although every care has been taken to ensure that the information in this document is accurate and up to date, Mark Roberts Motion Control continuously strives to improve their products and may make changes to the hardware, firmware, and software described in this document. Mark Roberts Motion Control therefore cannot be held responsible for any error or omission in this document.

All product names mentioned herein are the trademarks or registered trademarks of their respective owners.

Contact information	
Mark Roberts Motion Control Ltd.	
Unit 3, South East Studios	
Blindley Heath	
Surrey	
RH7 6JP	
United Kingdom	
Telephone:	+44 (0) 1342 838000
E-mail:	info@mrmoco.com (sales and general enquiries) support@mrmoco.com (customer support)
Web:	www.mrmoco.com www.mrmocorentals.com

Contents

Chapter 1	Assembling the hardware	1
	Safety.....	1
	Overview	1
	General procedure	3
	Adjusting the trolley	4
	Mounting the turret.....	5
	Mounting the main arm	6
	Mounting the lift arm.....	7
	Mounting the parallelogram fin and arm	8
	Mounting the weight cage.....	10
	Mounting the swan neck.....	11
	Mounting the head.....	12
	Connecting the cables	13
	PC - RT-14 - umbilical cable - base - turret connections.....	13
	Turret - arm connections.....	15
	Lift arm connections	16
	Lift arm limit and datum connections.....	16
	Lift motor connections	16
	Arm - swan neck - head connections.....	17
	Mounting Talos on a track.....	18
	Mounting Talos on the track bearings	18
	Attaching the track motor pinch wheel and its connectors.....	20
	Removing the trolley wheels	21
Appendix 1	Talos panels.....	24
	Panel summary.....	24
	Connector pin-out information	26
	Data In connector	26
	Data Out connector	26
	Camera Accessories connector	26
	Video connector.....	27
	Mains In connector	27
	Mains Out connector	27
Appendix 2	Specifications.....	28

Chapter 1 Assembling the hardware

Safety

- Due to the size and weight of Talos components, it is recommended that you use at least **two** people to assemble it.



- Do not use around flammable gas. All electrical equipment can generate sparks that can ignite flammable gas.
- Talos has powerful motors that can pinch, so take care not to get your hands trapped in the rig or cabling.
- Keep the equipment dry. The system has **not** been made weatherproof. Do not use with wet hands.
- Keep cables tidy. Use cable ties to keep them out of harm's way. If you have a head with slip rings then make use of them; avoid running any cables between Talos and the rotating head or camera if possible.
- Use a 240V AC power supply that is properly **earthed** (grounded). This is not only for safety reasons; electrical noise on an unearthed system can make axes controller boards trip out unpredictably, interrupting the shoot and creating intermittent problems that can be difficult to trace.

Overview

Thank you for using the Talos motion control rig from Mark Roberts Motion Control (MRMC). Talos is designed for reliable day-in, day-out use in professional studio and Outside Broadcast environments.

Talos is typically part of a complete motion control system that includes:

- **Talos** itself.
- The **trolley** wheels on which Talos is mounted. You can use Talos directly on wheels, or use the trolley wheels to lift Talos onto a **track** or alternative base. You can leave the trolley wheels on or remove them.
- A **head** such as an Ulti-Head or SFH-50, on which you mount your video camera.
- A Windows PC running **Flair** Motion Control Software.
- An **RT-12** or **RT-14** interface box, which handles the connections between the PC and the Talos rig.
- Additional **controllers** such as a Hand-Held Box (HHB), MSA-20 Handwheels or Pan Bars.

General procedure



1. Adjust the trolley - page 4.
2. Mount the turret - page 5
3. Mount the main arm - page 6.
4. Mount the lift arm - page 7.
5. Mount the parallelogram fin and arm - page 8.
6. Mount the weight cage and insert the weights - page 10.
7. Mount the swan neck - page 11.
8. Mount the head - page 12.
9. Connect the cables - page 13.
10. Mount Talos on a track - page 18. If you want, you can mount the Talos base onto the track first and then build Talos on the track starting with step 2.

Adjusting the trolley

You can adjust the width and height of the Talos trolley even when it is fully loaded with a complete rig. At its narrowest setting Talos can fit through a standard 76 cm (30 inch) doorway if you remove the height adjustment cranks. (These pull off by hand.)

For maximum stability when building Talos or shooting you should use the widest, lowest trolley setting that is practical. You set each wheel column independently, one at a time, as shown below.

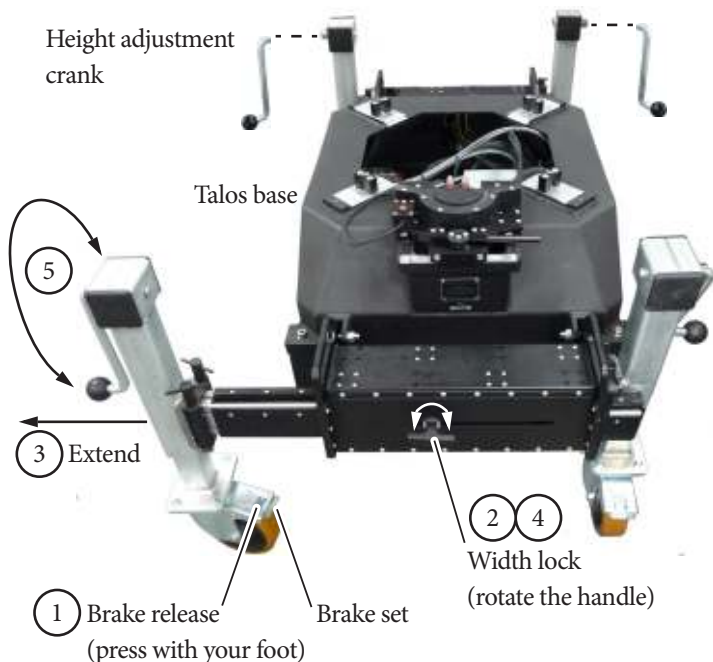

1. Release the wheel brake. The brake affects both pivot and rotation.
2. Loosen the width lock by unscrewing the handle one or two rotations. There is a separate lock for each wheel column.
3. Pull the wheel beam out of the housing, to extend the trolley width.
4. Re-tighten the width lock.
5. Turn the Height adjustment crank to raise or lower the column. Adjust the height of the columns relative to each other to remove any wobble in the base.

Mounting the turret

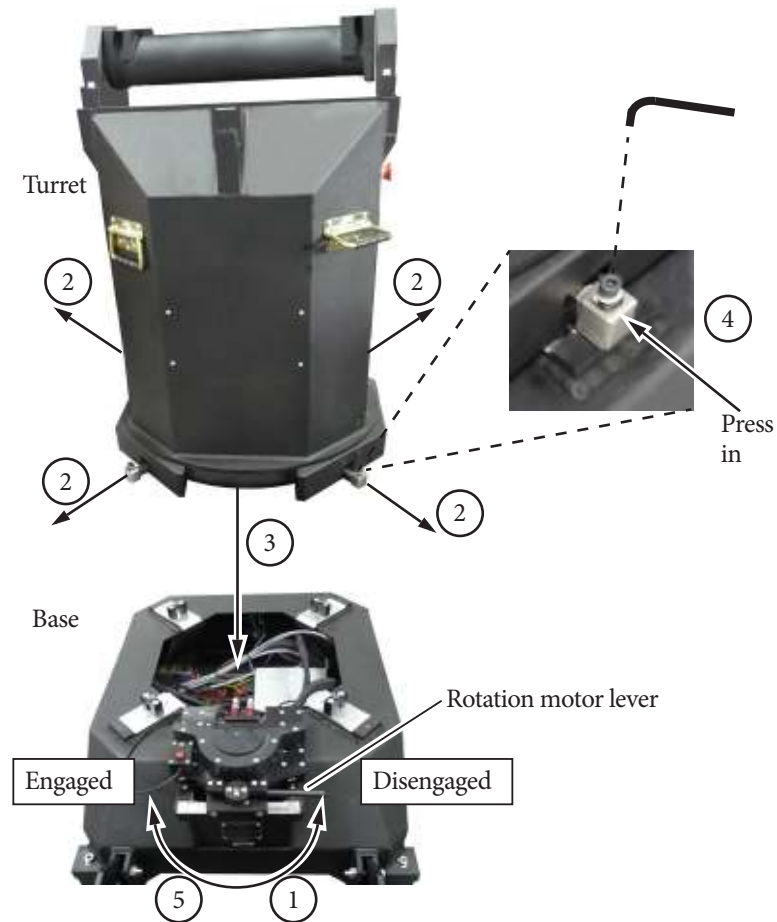

1. Make sure the rotation motor lever is in the anti-clockwise (Disengaged) position.
2. Make sure all four turret bolt retainers are fully extended outward.
3. Lower the turret onto the base.
4. Press the four turret bolt retainers all the way into the turret, and tighten the bolts down into the base.
5. Move the rotation motor lever to the Engaged position.

Mounting the main arm

Hint

It is useful to have a movable table that you can use to hold up the free end of the main arm while you tighten the bolts at the other end.



1. If your parallelogram arm was stored or shipped inside the main arm, remove the parallelogram arm and set it aside for later.
2. Rotate the cylinder on top of the turret so the brackets on the cylinder face up.
3. Place the main arm onto the brackets on the turret cylinder.
4. Insert and tighten the six bolts that hold the arm on the cylinder.

Mounting the lift arm

1. Open the lift arm clamp on the underside of the main arm.

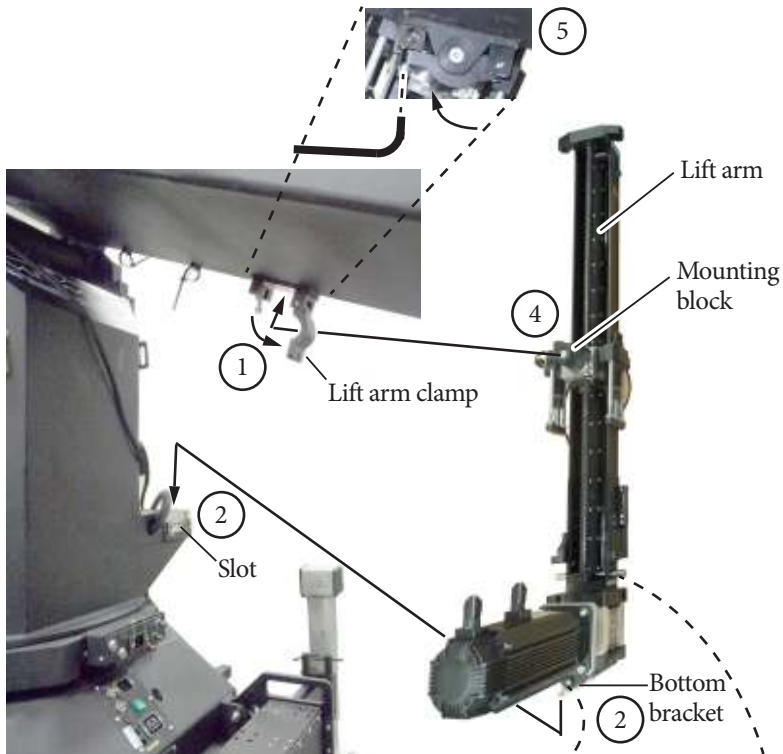

2. Insert the bottom bracket of the lift arm down into the slot on the turret.
3. Tighten the two bolts on the bottom bracket to hold it in place.
4. Raise the main arm and position the lift arm to put the mounting block, flat side up, into the open clamp.
5. Close the clamp and tighten the bolt.



Mounting the parallelogram fin and arm

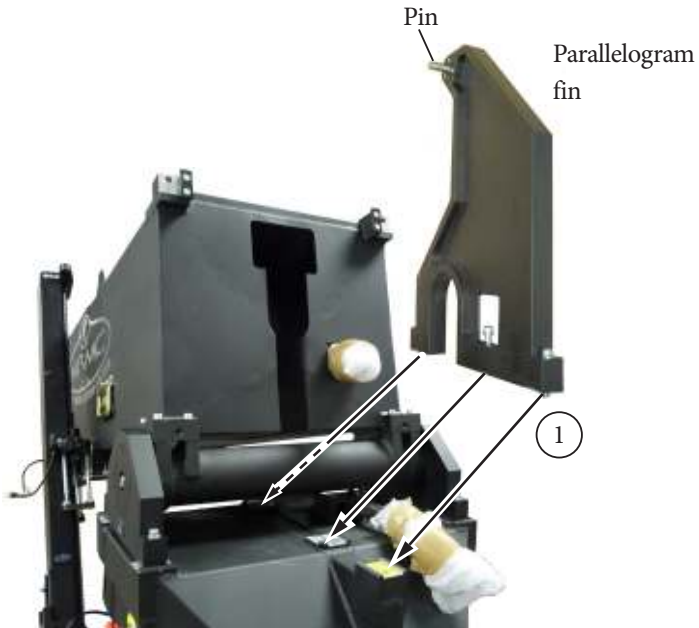

1. Mount the parallelogram fin onto the top of the turret, over the cylinder, and tighten the three bolts that hold the fin in place.



2. Open the clamps on the parallelogram arm.



3. Insert the parallelogram arm into the main arm, clamps first, all the way to the parallelogram fin at the rear of the rig.

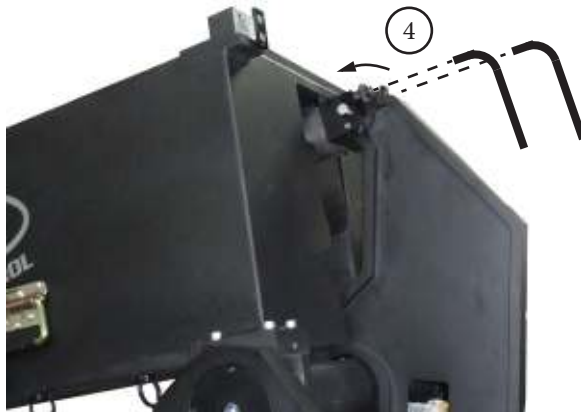

4. At the rear of the rig, close the parallelogram arm clamps around the pins at the top of the fin and tighten the clamp bolts.

Mounting the weight cage

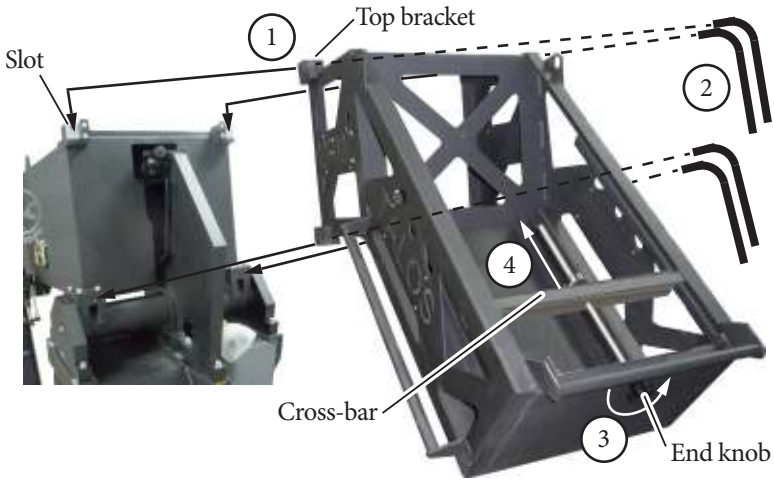

1. Insert the top brackets of the weight cage down into the slots at the top rear of the main arm.
2. Tighten the four corner bolts that hold on the weight cage onto the main arm.
3. Unscrew the end knob from the threaded weight retaining rod, and remove the knob.
4. Slide the weight retaining rod and its cross-bar up in the cage, out of the way.

5. Add weights to the bottom of the cage. Talos typically requires 6 to 7 weights, depending on the weight of the head and camera used. The weights are 13Kg each.

6. Replace the retaining rod and end knob, going through the holes in the weights.
7. Adjust the knobs on the rod so that the cross-bar holds the weights firmly in place.



Mounting the swan neck

Note that you can mount the swan neck the other way up by removing and swapping around the bottom brackets and parallelogram arm clamps on the neck, before mounting the neck.

1. Open the parallelogram arm clamps on the side of the swan neck.

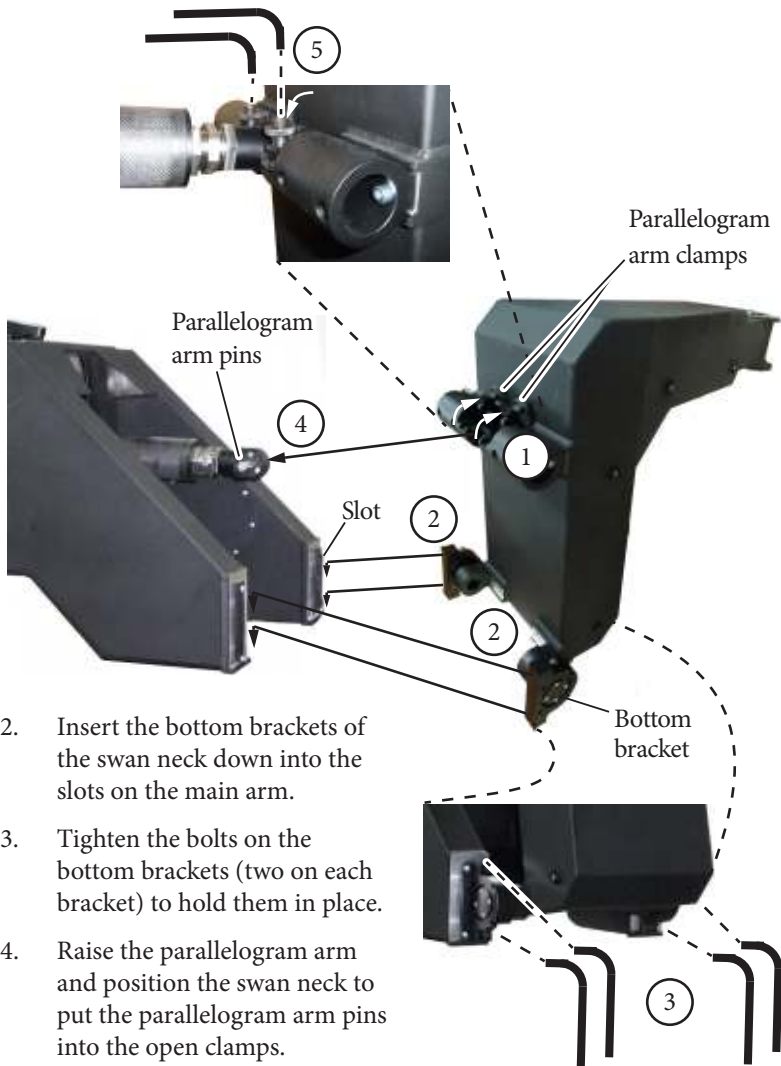

2. Insert the bottom brackets of the swan neck down into the slots on the main arm.
3. Tighten the bolts on the bottom brackets (two on each bracket) to hold them in place.
4. Raise the parallelogram arm and position the swan neck to put the parallelogram arm pins into the open clamps.
5. Close the parallelogram arm clamps and tighten the bolts.

Mounting the head

You can mount the head under-slung as shown or over-slung.

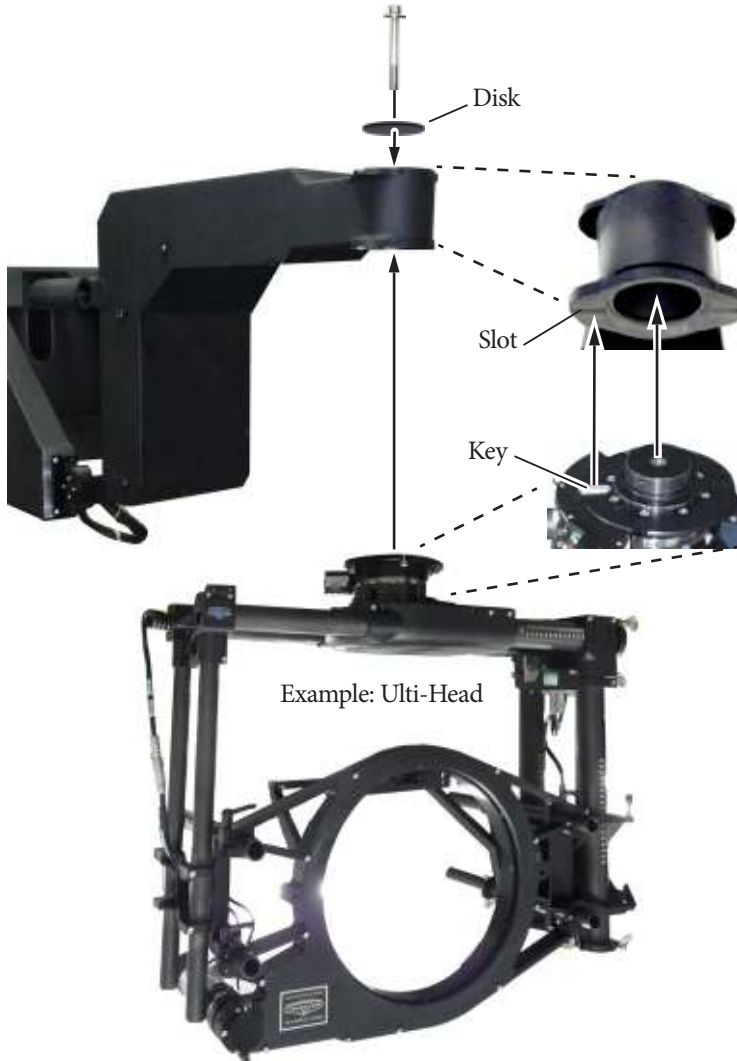

- ◆ Mount the head to the swan neck with the single bolt and disk, making sure that the key on the head fits into the slot in the neck.

Connecting the cables

PC - RT-14 - umbilical cable - base - turret connections

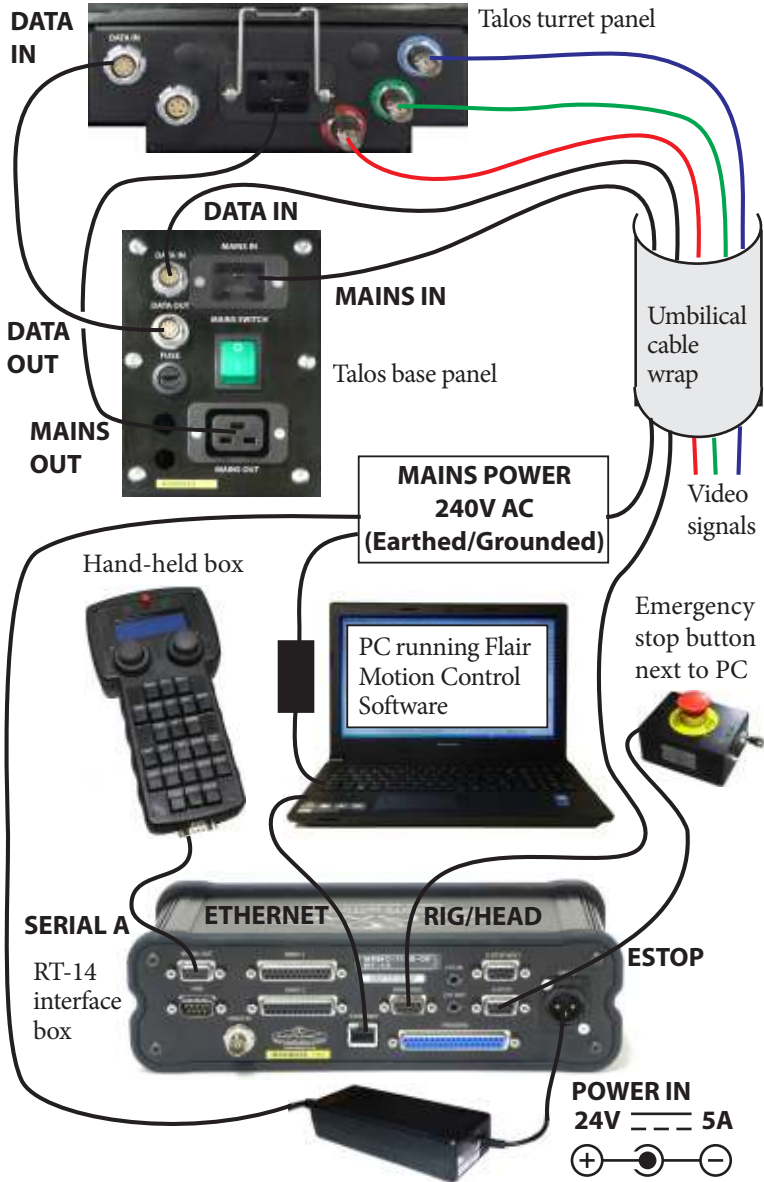

Picture of umbilical - base - turret connections:

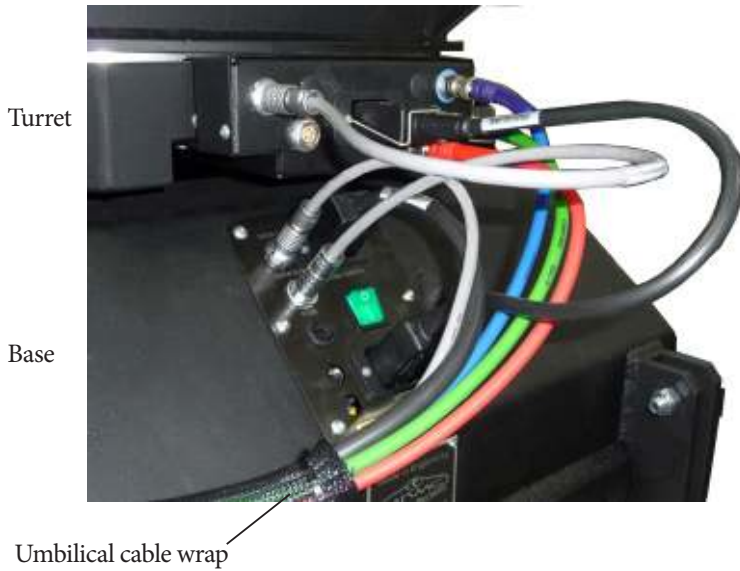

Turret - arm connections

Cables going into
the main arm

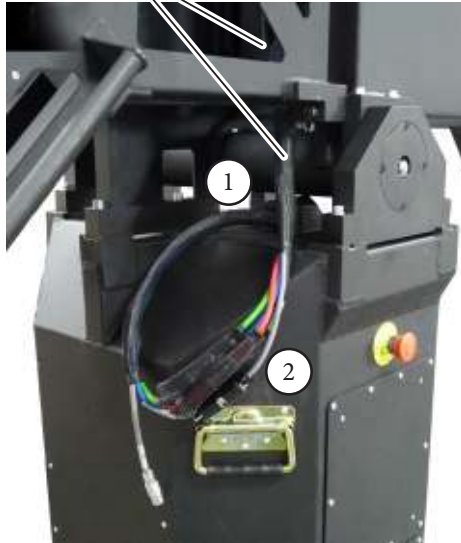

1. Pull about 0.5 metres of the two collections of cables from the hole in the top of the turret.
2. Connect the cables in the larger collection to those that go into the main arm. These are the main cables for the head and camera.

The smaller cable collection coming from the top hole in the turret is for the lift arm limit and datum connections, described in the next section.

Lift arm connections

Lift arm limit and datum connections

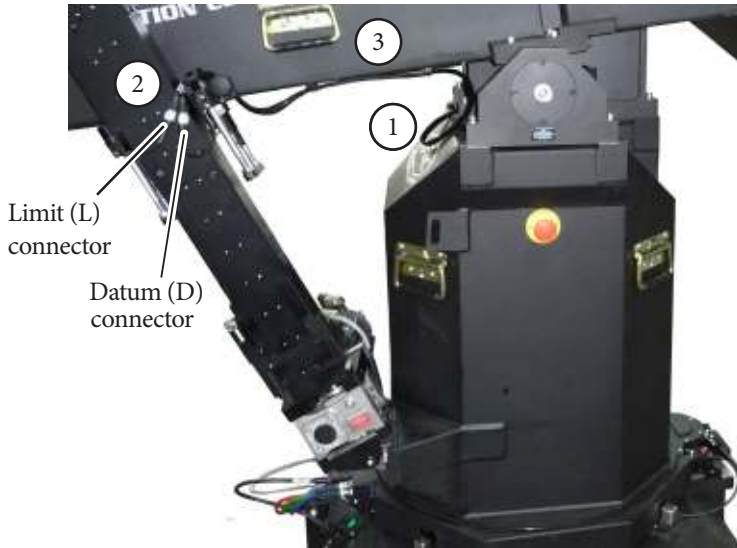

1. Pull about 1 metre of the lift arm limit/datum cable collection out of the top of the turret.
2. Attach the cable ends to the Limit (L) and Datum (D) connectors on the lift arm.
3. Use cable ties to attach the cable to the main arm.

Lift motor connections

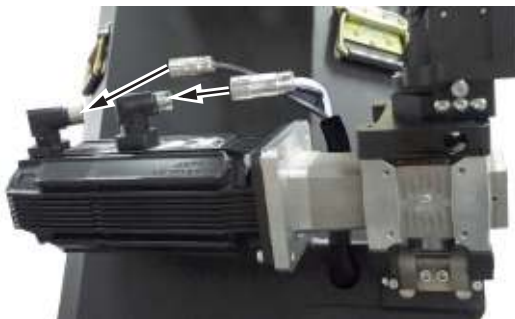

Arm - swan neck - head connections

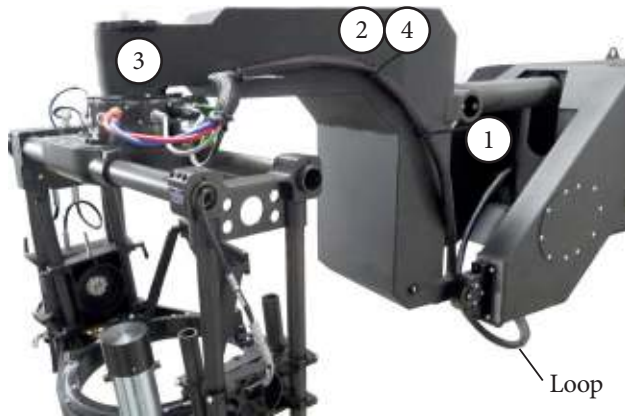

1. Pull several metres of the main head/camera cable collection out of the front of the main arm. Pull out enough to reach the head and camera, and enough to make a free-hanging loop between the arm and swan neck to avoid subjecting the cable to any tension or sharp flexing during use.
2. Use cable ties to loosely attach the cable to the swan neck, to help support the cable, but leave enough slack in the ties for now to allow adjustment of the cable length.
3. Attach the connectors to the head and camera as required.

Example: Connections to the slip ring base on the Ulti-head:



4. Tighten the cable ties on the swan neck.

Mounting Talos on a track

Mounting Talos on the track bearings

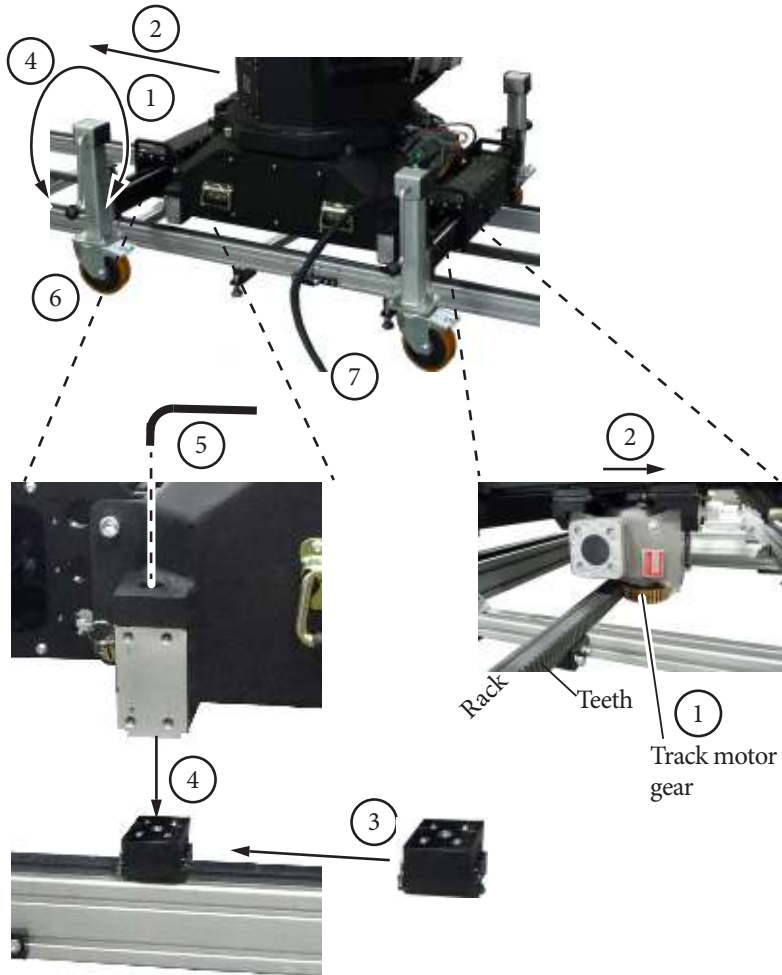

1. Roll Talos to a position just off the end of the track, use the wheel cranks to raise Talos on its wheels high enough to go over the track, and high enough that the track motor gear on the underside of the rig completely clears the rack (the middle rail on the track). Rotate Talos on its wheels to be the correct way around so that the track

motor gear on the Talos underside is on the toothed side of the rack. **Do not engage the teeth yet; just make sure Talos is the correct way around for the track.**

2. Roll Talos on its wheels over the track about a metre.
3. Push the four Talos track bearings onto the ends of the track (two on each rail) and into position under the four corners of the Talos base.

Hint

Always mount and remove the track bearings with care. Try to keep them squared up and in-line with the bearing rail to avoid damaging them or loosing a bearing.

4. Carefully lower Talos onto the four track bearings, making sure that all four bearings are aligned with the corners of the Talos base, and the track motor gear on the underside of Talos clears the rack. (The track motor gear is on bearing rails so you can slide it out of the way to clear the rack.)
5. Tighten the four track bearing mounting bolts at the corners.
6. Apply the brakes to the wheels to keep them from pivoting against the track (the brakes affect both rotation and pivot), and raise the wheels off the ground so the full Talos weight is taken by the track.
7. Feed out enough umbilical cable from your control area to reach the entire length of the track without stretching the cable. Make sure the area alongside the track is clear so that the umbilical cable doesn't catch on anything when Talos drags it alongside the track.
8. Attach the track motor pinch wheel on the underside of Talos, described in the next section.

Attaching the track motor pinch wheel and its connectors

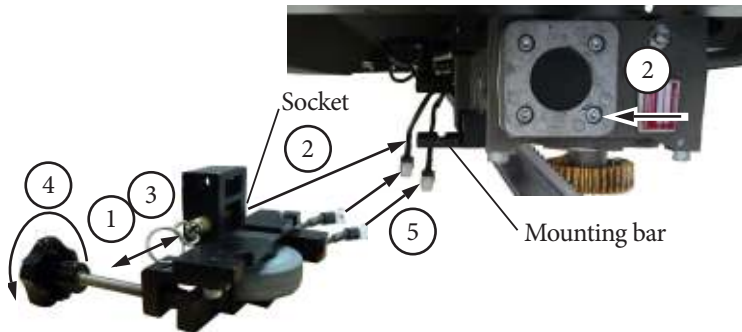

1. On the separately supplied pinch wheel assembly, remove the brass retaining pin by pulling on the ring.
2. Mount the pinch wheel assembly onto the track motor on the Talos underside, by sliding the track motor gear against the rack (the motor is on bearing rails) and putting the pinch wheel Socket onto the track motor Mounting bar.
3. Replace the retaining pin in the pinch wheel assembly by pushing on the ring (not the locking sleeve), to hold the assembly in place on the track motor.
4. Hand-tighten the pinch wheel adjustment bolt so that the rubber wheel presses firmly against the smooth side of the rack. This holds the track motor gear firmly against the toothed side of the rack.
5. The pinch wheel assembly has sensors for detecting the Limit (L) and Datum (D) magnets on the track. Connect the cables for these sensors to the corresponding connectors on the Talos underside, and use cable ties to hold them securely up away from the track.

Removing the trolley wheels

If you mount Talos onto a track or permanent base then you can remove the two trolley wheel units that are on either side of the Talos base.

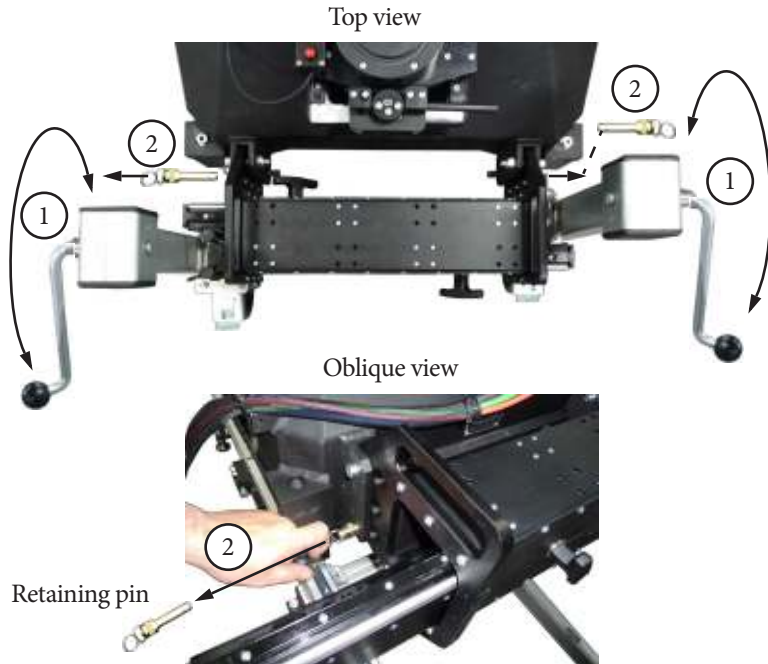

1. With the base of Talos supported by the track or other base mount, turn the crank on each end of the wheel unit so that the wheels are suspended in the air, just above the ground.
2. Lift the wheel unit slightly to take the stress off the brass retaining pins, and pull out the retaining pin at each end of the wheel unit.

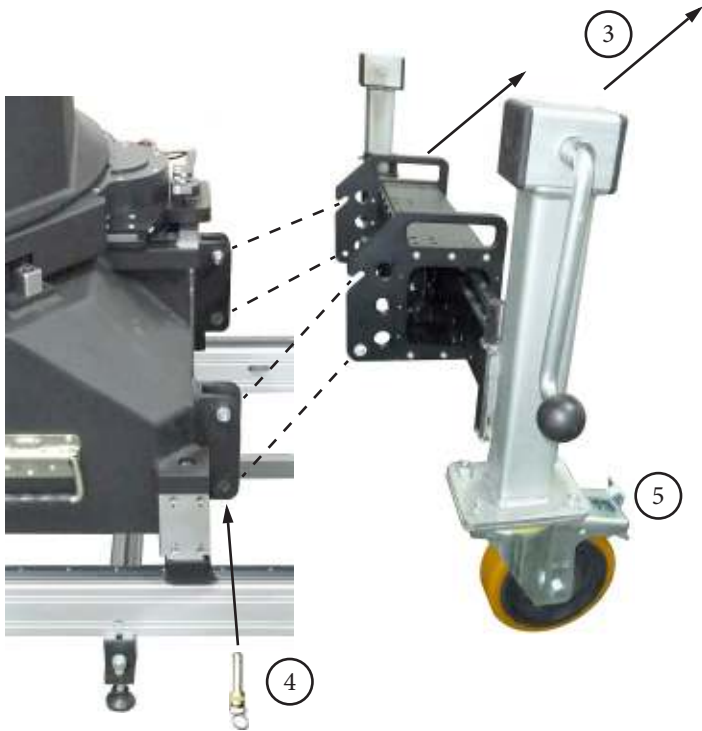

3. Lift the wheel unit away from the Talos base.
4. Insert the retaining pins back into the Talos base, for safe keeping.
5. If you are going to store the wheels for weeks or months, release the wheel brakes so they don't leave a dent in the wheel rubber. You can also retract the wheels into their narrowest position if you want.

Appendix 1 Talos panels

Panel summary

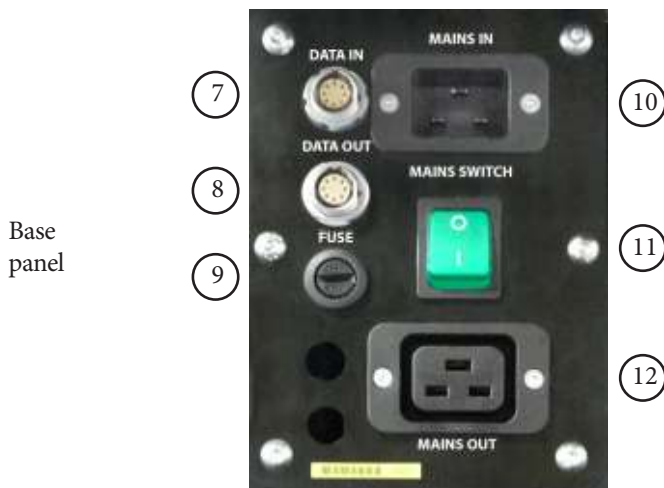

1. **DATA IN** DataLink In (Up Link) connector for controlling the upper parts of Talos, namely, the lift arm and the head. You normally attach this to the **DATA OUT** connector on the Talos base. For pin-out information see *Data In connector* on page 26.
2. **CAM ACC** Camera Accessories input/output connector. For pin-out information see *Camera Accessories connector* on page 26.

3. **MAINS IN** power input connector, 240V AC, for the lift arm, head, and camera. Note that the turret has a built-in transformer that supplies 34 Volts DC power to the head and camera, via one of the cables in the main cable collection that goes to the head.
- 4, 5, 6. **VIDEO** connectors for sending or receiving signals to and from the head and/or camera. This uses standard coaxial cable which can be used for video, trigger, and sync signals.
7. **DATA IN** DataLink In (Up Link) connector, for controlling Talos. You normally connect this to the **RIG/HEAD** connector on an RT-12 or RT-14 interface box, which in turn is connected to a PC running Flair Motion Control software. For pin-out information see *Data In connector* on page 26.
8. **DATA OUT** DataLink Out (Down Link) connector, for connecting additional devices to the DataLink network. You normally connect this to the **DATA IN** connector on the Talos turret to control the upper parts of Talos (lift arm and head). For pin-out information see *Data Out connector* on page 26.
9. **FUSE** with a rating of 16 Amps.
10. **MAINS IN** power input connector, 240V AC, used to power Talos and the attached head and camera.
11. **MAINS SWITCH**. You should only turn on Talos when all mechanical parts are securely mounted in place and all cables are connected.
12. **MAINS OUT** connector, 240V AC. You normally connect this to the **MAINS IN** connector on the Talos turret to power the upper parts of Talos (lift arm, head, and camera). For pin-out information see *Mains Out connector* on page 27.

Connector pin-out information

Data In connector

This is a DataLink In (Up Link) connector. For usage see page 24 and page 25.

1. WATCH-DOG-
2. UP-OUT-
3. UP-OUT+
4. UP-IN-
5. UP-IN+
6. WATCH-DOG+
7. ESTOP (+5V)
8. ESTOP (GND)

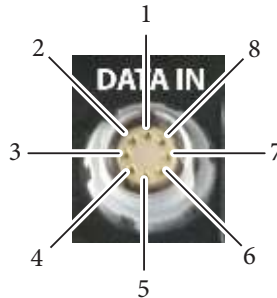

Data Out connector

This is a DataLink Out (Down Link) connector. For usage see page 25.

1. WATCH-DOG-
2. UP-OUT-
3. UP-OUT+
4. UP-IN-
5. UP-IN+
6. WATCH-DOG+
7. ESTOP (+5V)
8. ESTOP (GND)

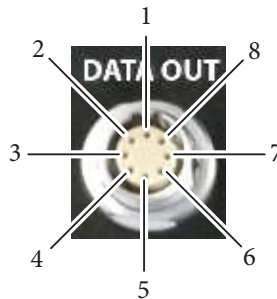

Camera Accessories connector

The Camera Accessories connector is for controlling various aspect of the camera.

1. CAM RETURN
2. CAM REVERSE
3. CAM SYNC
4. CAM STOP
5. CAM START

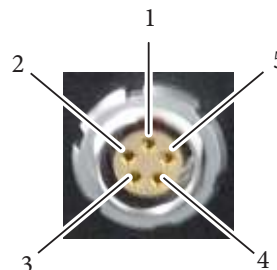

Video connector

The VIDEO connectors use standard coaxial cable, and can be used for video as well as other general-purpose signals such as trigger and sync.

1. VIDEO (inner)
2. GND (outer)
- 3.

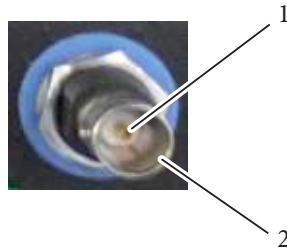

Mains In connector

Power input connector for Talos and its attachments. 240 Volts AC.

1. Earth
2. Live
3. Neutral

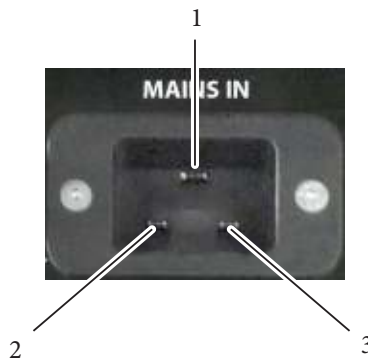

Mains Out connector

Power output, usually connected to the Mains In connector on the Talos turret to power the lift arm and camera. 240V AC.

1. Earth
2. Live
3. Neutral

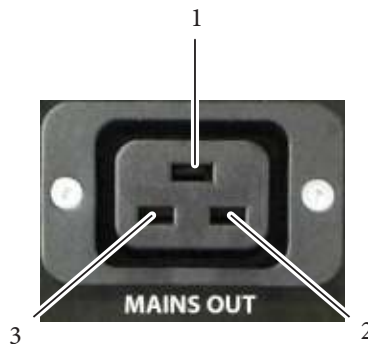

Appendix 2 Specifications

Weight: 492 Kg (1085 lbs) including trolley wheels and 10 counterweights

Payload (camera and head): 40 Kg

Power requirements: 110-240 Volts AC (earthed/grounded). 110 Volts will push Talos at half speed.

Temperature range: 0-45 °C (32-113 °F)

Humidity tolerance: 0% to 85% relative humidity, non-condensing

Dimensions:

Length: 3270 mm

Width (without trolley wheels): 706 mm (28 in)

Width (with trolley wheels) 737-1175 mm (29-46 in)

Height (on trolley wheels, horizontal arm): 1960 mm (77 in)

Notes

Notes

Notes



Mark Roberts Motion Control Ltd.

Unit 3, South East Studios, Blindley Heath, Surrey RH7 6JP

United Kingdom

Telephone: +44 (0) 1342 838000

info@mrmoco.com

www.mrmoco.com

